

SGM MAGNETICS

Enquiry form



Horizontal eye coils

General Information:

Company name		
Person to contact		
Position		
E-mail address		
Phone no.		Fax no.
Address		
Your SGM Contact	Name:	Email
	Phone no.	Fax no.

Coil specifications:

Inner diameter	Min. mm/inches	Max. mm/inches
Outer diameter	Min. mm/inches	Max. mm/inches
Width	Min. mm/inches	Max. mm/inches
Weight	Min. Metric tons/US tons	Max. Metric tons/US tons
Smallest coil OD presenting the maximum weight	mm/inches	
Steel gauge	Min. mm/inches	Max. mm/inches
Are coils zinc coated?	<input type="checkbox"/> No	<input type="checkbox"/> Yes, thickness micron
Temperature	<input type="checkbox"/> Ambient	<input type="checkbox"/> Hot (>150 °C / 300 °F)
For hot coils only		
Standard surface temperature	°C/°F	
Maximum surface temperature	°C/°F	
Standard time per magnet lifting cycle	seconds	
Standard quantity of lifts per hour		
Maximum lifts per hour		
Are there any stops in operation?	<input type="checkbox"/> No <input type="checkbox"/> Yes, every time for time	

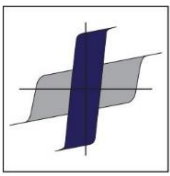

SGM MAGNETICS

Enquiry form



Coil wrapping specifications:

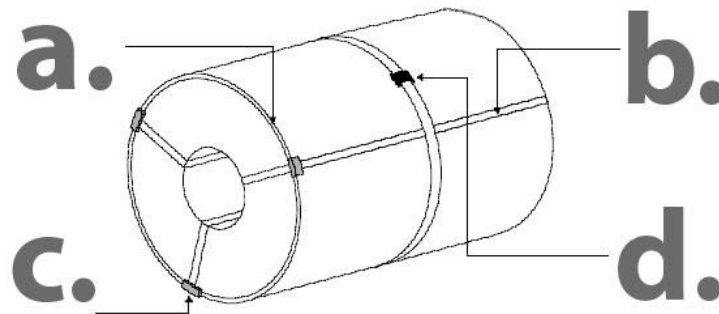

Wrapping:			
Turns	Thickness	mm / inches	
Straps:			
Number of radial straps	Number of diametric straps	Strap thickness	mm / inches
Edge protection:			
Width	mm / inches	Thickness	mm / inches
Strap closing clips:			
Thickness	mm / inches	<input type="checkbox"/> Can be everywhere	<input type="checkbox"/> Upper part can be avoided

Crane specifications:

Crane capacity	Metric tons/US tons		
Crane rated voltage		<input type="checkbox"/> Vac	<input type="checkbox"/> Vdc
Crane working environment		<input type="checkbox"/> Indoor	<input type="checkbox"/> Outdoor

Remarks:

Preferred solution:			
<input type="checkbox"/> Electro-magnet	<input type="checkbox"/> Battery back-up requested		
<input type="checkbox"/> Electro-permanent magnet			
<input type="checkbox"/> No preference			
Process stage:			
<input type="checkbox"/> Hot rolled	<input type="checkbox"/> Cold rolled	<input type="checkbox"/> Shipping bay	<input type="checkbox"/> Else, please specify

Notes: